

OPTRA



OPTRA Open Plan Square Lay-in with Peakform Prelude XL 24mm Exposed Tee grid

BENEFITS

- High acoustic performance
- High light reflective finish
- Cost effective
- Appealing smooth surface
- RH95 Humidity Resistant
- Sustainable – Green Star contribution

APPLICATION AREAS

- Open plan offices
- Call centres
- Retail
- Healthcare
- Education
- Theatres / auditoriums

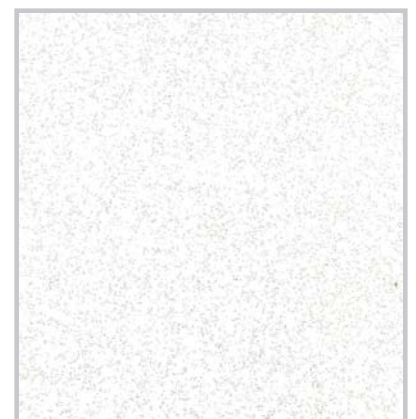

Inspiring Great Spaces

Armstrong[®]
CEILING SOLUTIONS

OPTRA



Colours available



RH95 Humidity Resistant



Product Handling Durability



80% Recycled Content EN ISO 14021



88% Light Reflectance

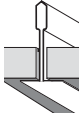
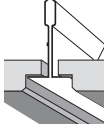
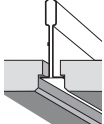
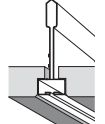
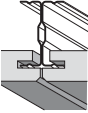

Acoustical Comfort

Panel Options	SQUARE LAY-IN	BEVELLED TEGULAR	BEVELLED TEGULAR		K2C2 EDGE
	 Prelude 24mm Grid	 Prelude 24mm Grid	 Suprafine 15mm Grid	 Silhouette 15mm Grid	 Modular Grid
600 x 600 x 15mm	G600W060615S	G600W060615TL	G600W060615ML		–
1200 x 600 x 15mm	G600W061215S	G600W061215TL	G600W061215ML		#
1200 x 1200 x 20mm	G600W1212120S	*	*		–

– Not available

* Special sizes and profiles available upon request.

K2C2 items are 20mm thick.



NRC: 0.90: 15 and 20mm panels
0.95: 25mm (available upon request)



RH95% at 4°C – 30°C



Conforms with BCA Spec. C1.10 and tested to AS/NZS 3837:1998
– Group 1, ISO 5660 – Group 1 –S



Thermal Insulation (R- Value)
0.47 m²K/W



1.88kgs/m² (15mm)
2.38kgs/m² (20mm)

Material

Biosoluble glass wool

Surface Finish

Factory-applied vinyl latex paint with painted (fully sealed) edges

Backloading Recommendation

Contact your local Armstrong representative

Colour Options



WH–Global White
RAL9016



BL–Black
RAL9005



RAL colours available
upon request

Suspension Systems

PeakForm Steel options above, with 'Blue Tongue' Aluminium upon request

Green Star: Potential contribution

MAN		IEQ		ENE	MAT and Mat. Calc.		
Waste Management	Daylight Factor	Noise Levels	Emissions	Energy	Modular & Design for Disassembly	Product Stewardship	Recycled Content
✓	✓	✓	✓	✓	✓	✓	✓



Armstrong World Industries Pty Ltd
www.armstrongceilings.com.au

NSW
Telephone (02) 9748 1588

VIC/TAS
Telephone (03) 8706 4000

QLD/NT
Telephone (07) 3809 5565

Email: scentre@armstrongceilings.com

©2017 Armstrong World Industries Pty Ltd

AWP0417

Printed on Zanders Mega Recycled paper

Inspiring Great Spaces

Armstrong[®]
CEILING SOLUTIONS