

Step Lift Platform Specification

Pit: No pit required:
Drive: Electro-hydraulic
Speed: 0.1m/sec
Travel: Max 1m (Lower FFL to Upper FFL)
Power: 240v 20amp 1 phase 50hz
Stops: 2
Colour: Standard - RAL 9006
Lift platform: Special - RAL
Colour: Standard - RAL 9006
Upper gate: Special - RAL

Upper Gate Type

- Standard - Manual interlock (Push to open)
- Special - Motorized interlock (opens with motor)

Upper Gate Handling
 (Drawing shows - left hand)

- Right hand handling
- Left hand handling

Upper call station

- Standard - Gate mounting (opposite to handling side)
- Special - Wall mounted (surface mounted)
- Special - Wall mounted (recessed)

Lower call station

- Standard - Wall mounted (surface mounted)
- Special - Wall mounted (recessed)

Hydraulic pump

Housed in section below the gate. If travel is less than 400mm an external Pump box is required

Building work required

- 1- Provide 20amp 1 phase power to lockable isolator (close to lift).
- 2- Provide a level surface under the lift base.
- 3- Provide clear delivery access to lift location. A minimum of 1370mm width.
- 4- Provide adequate fixing point for the upper gate.
- 5- Provide 20 mm conduit + draw wire from lower call station to under gate frame.
- 6- If wall mounted call station on upper landing, also provide a conduit to under gate.
- 7- Provide a cable from the isolator to under the gate frame + a 3m extra tail.
- 8- Provide finish floor on the lower and upper landing.
- 9- Provide base under lift to withstand a load of 500 kg.

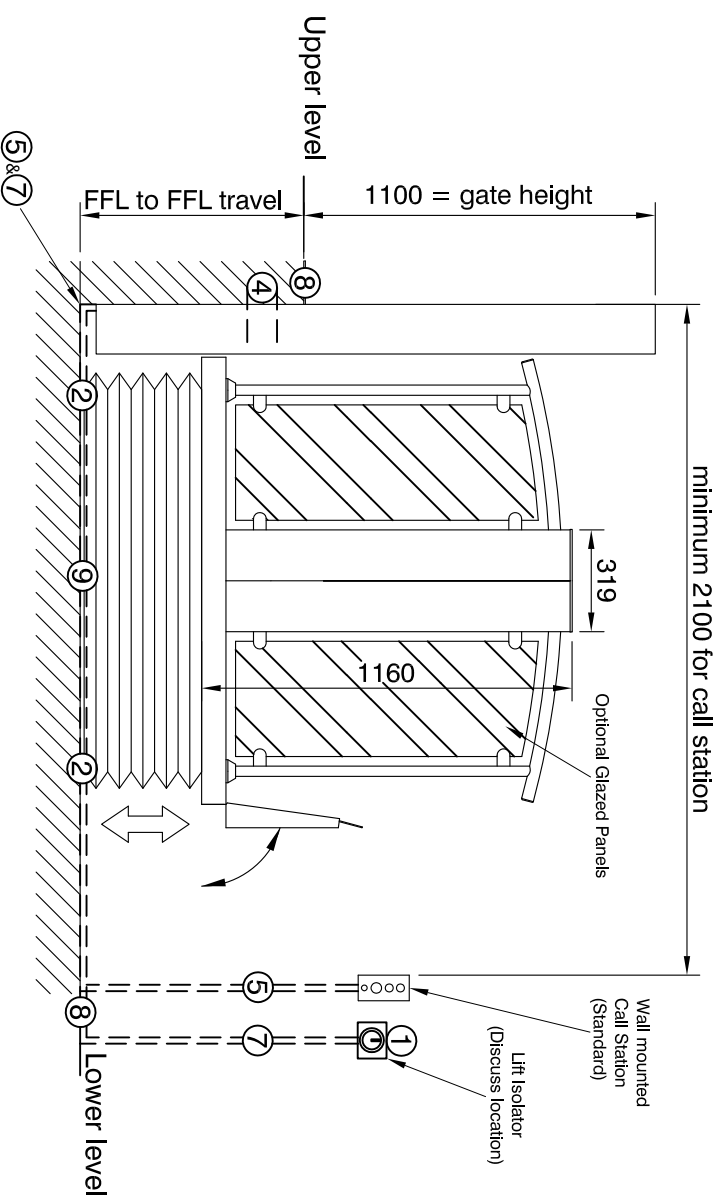

| | | | |
|--------------------------------|-----|--|-------|
| | | TITLE 1M Independence - THRU | |
| LIFT NO. 1M IND-THRU | | REV B | |
| SCALE | NTS | DATE | DRAWN |
| | | 27/05/2011 | CH |

Unit 34, 49/51 Mitchell Road
 Brookvale NSW 2100
 Tel - 1300 884960
 Fax - 02 85805048
 E-mail - info@platformliftco.com.au
 Website - www.platformliftco.com.au