

INTRIM®

RAILING REVIT FAMILIES

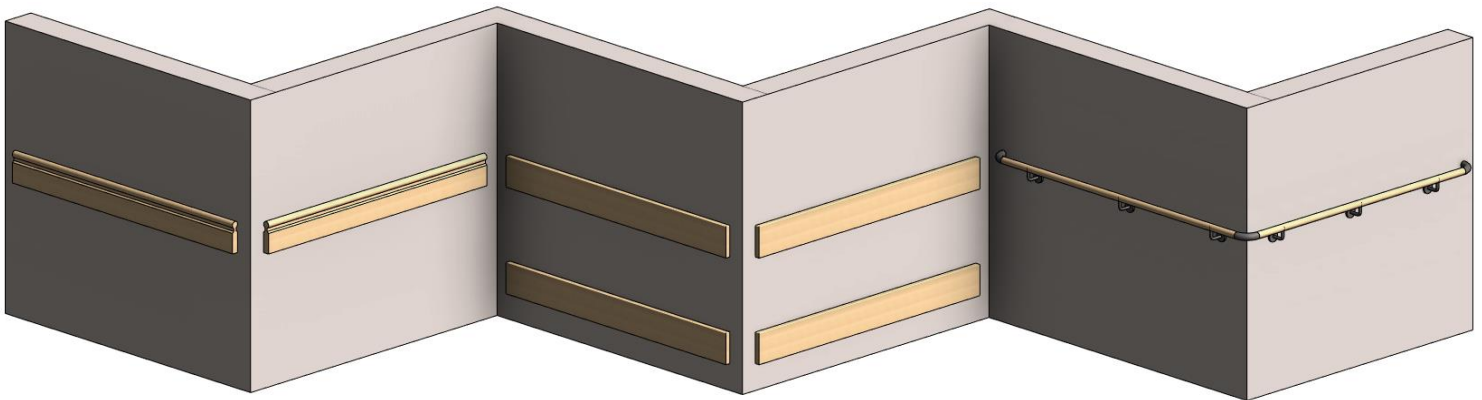

HANDRAIL - IHR10



BUMP RAIL – BR04



CONNECTA RAIL

CONTENT OVERVIEW	2
DRAWING / PLACING RAILINGS	2
END CONDITIONS	3
CONNECTA RAIL	4

CONTENT OVERVIEW

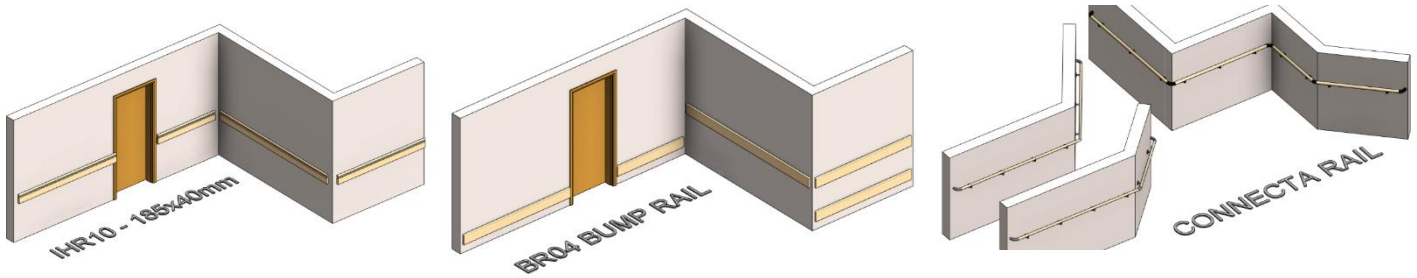

The Intrim railing Revit families have all been created as Line-Based components. This approach was used in favour of in-built Revit railing system families in order to achieve a higher level of control and accuracy. Each has been categorised appropriately for ease of locating the railings directly within the project browser, and can all be quantified in a Railing schedule. Each family also has in-built detail level control to suit the design phase.

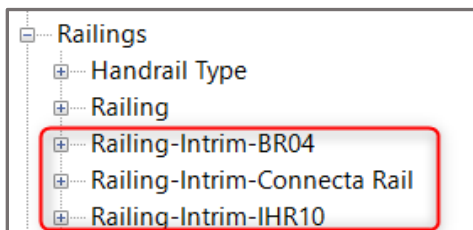

Course Detail:



Medium/ Fine Detail:



DRAWING / PLACING RAILINGS

Being that all of the families are Line-Based, a similar approach is taken in creating and controlling each of the railings within the Revit project environment. This involves first specifying if the railing is to be placed on a Face or a Work Plane. The Place on Face option is preferred where railings are to follow the slope of any ramps or sloping floor surfaces.

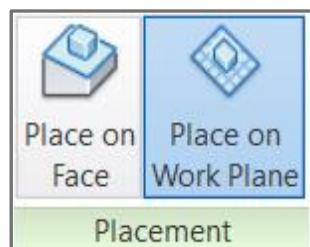

There are a range of drawing options, the most likely to be used being the Line and Pick Lines options. Selecting the Line option allows specifying a start and end point free of any constraints. Pick Lines will allow the placement of railings based on any existing walls or faces in the project. It is recommended that while drawing the railings, the padlock be activated to ensure the position of the railing updates with any changes to size or location of the hosting wall(s).

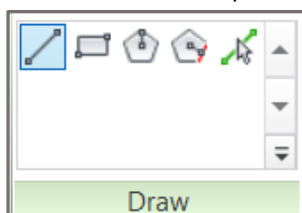

END CONDITIONS

When selected, each of the railing families will display the numbers 1 and 2 in Plan and 3D Views to assist in identifying the corresponding end condition parameter (**End 1 Condition / End 2 Condition**) for setting of the appropriate end condition i.e. Internal Corner, External Corner, Wall End etc.

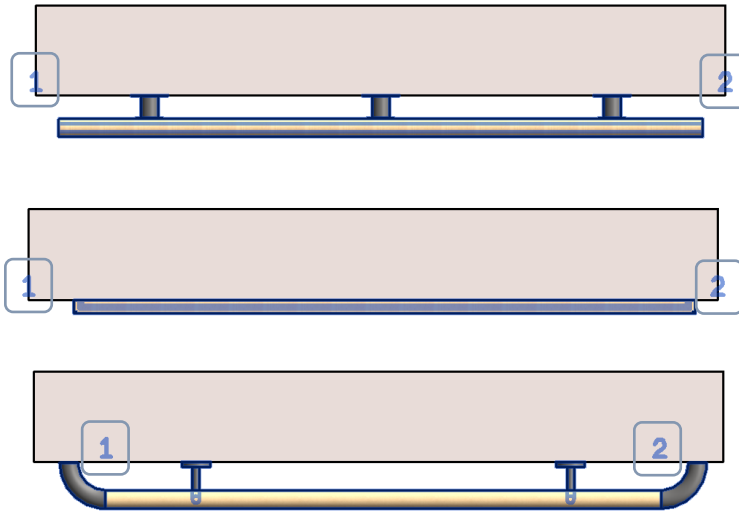

The IHR10 and BR04 railing families will automatically generate clearance zones based on the input to the **End 1 Condition** and **End 2 Condition** instance parameters. These parameters provide independent control over the conditions of both ends of any instance of railing and will update the **End 1 Clearance & End 2 Clearance** parameters. These clearances and the resulting handrail length are then reflected in the calculated **Length_ANZRS** parameter. The 2D and 3D visual representation of these clearance zones can be displayed or hidden toggling on/off the **Show End Clearances** type parameter.

Properties

Railing-Intrim-IHR10 Standard

Railings (1) Edit Type

Constraints

End 1 Condition: End Condition: Internal Corner

End 2 Condition: End Condition: External Corner

Length: End Condition: External Corner

Offset: End Condition: Internal Corner

Work Plane: End Condition: Wall End

Dimensions: End Condition: Window or Door

Length_ANZRS: 2000.0

Identity Data

Image

Comments

Mark

Phasing

Phase Created: New Construction

Phase Demolis...: None

Visibility

Show Warning:

Other

Bracket Count: 3

End 1 Clearance: 150.0

End 2 Clearance: 50.0

$$\text{Length_ANZRS} = \text{Length} - (\text{End 1 Clearance} + \text{End 2 Clearance})$$

CONNECTA RAIL

While the Connecta Rail family is also a line-based loadable component and is placed in much the same way as the IHR10 and BR04 railings, some additional functionality has been built-in to accommodate for additional components and connection conditions.

When a 45° or 90° angle is selected for either the **End 1 Corner Angle** or **End 2 Corner Angle** parameters, a corresponding bracket will be introduced and added to the Railing schedule. Should any other angle be specified the railing will automatically adjust to achieve the correct extension to achieve an even mitre joint between the two lengths.

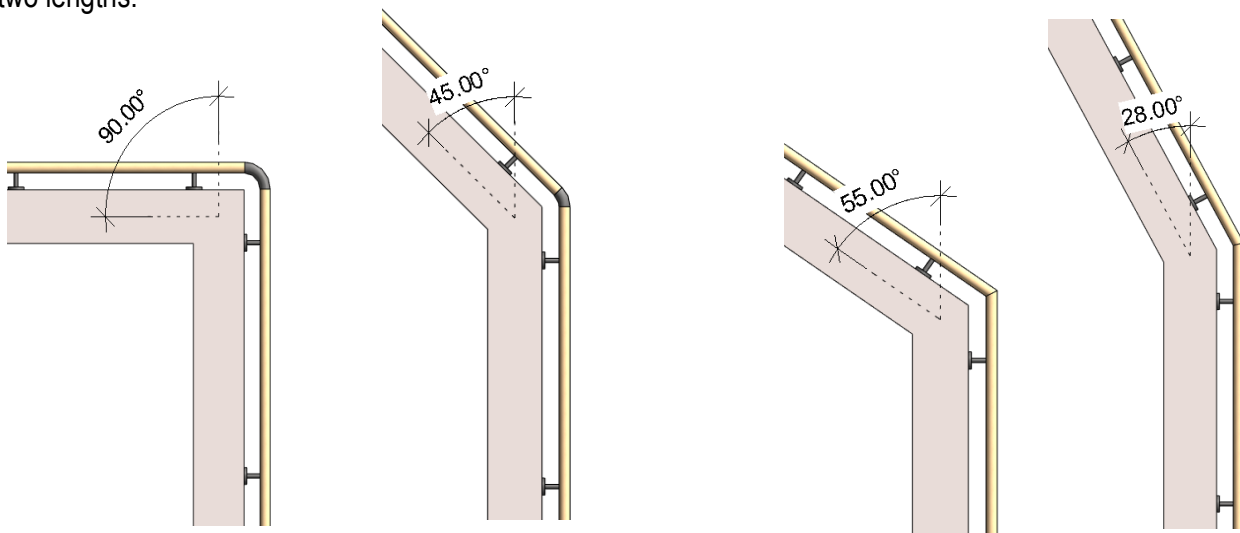

For continuous railings with a 45° or 90° angle bend, there will be a duplication of brackets and as such it is important to ensure the **Show End 1 Termination** or **Show End 2 Termination** visibility parameter is updated to ensure only one instance is displayed in the geometry and Railing schedules.

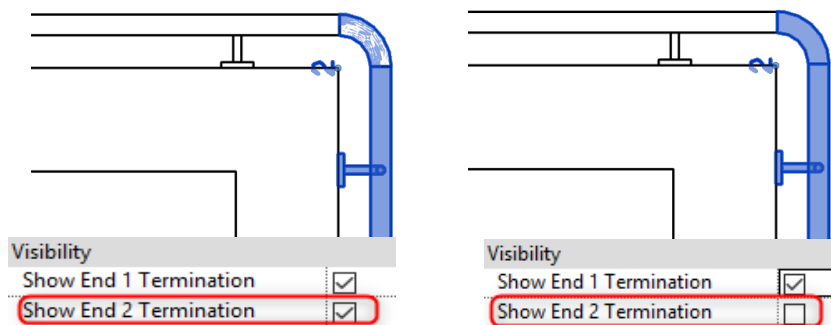

The Connecta Rail bracket type can be changed using the **Bracket Type Selector** parameter which will in turn update the Railing schedule to display accurate quantities and product codes of selected bracket.

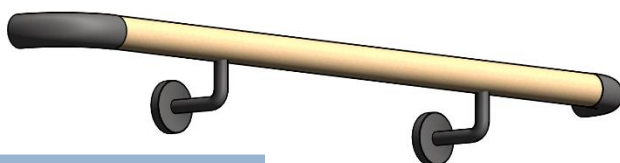

Other	
Bracket Type Selector	1
Bracket Type	HB03S

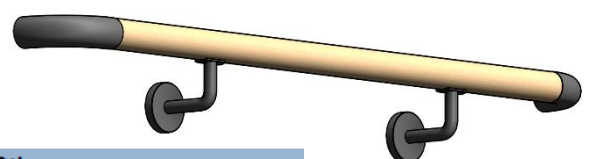

Other	
Bracket Type Selector	2
Bracket Type	HB02CS