

FBC16

Driglaze Balustrade Channel

FBC16 can be installed in the concrete slab during casting, and the glass simply installs in the same way as the FBC15. This provides a completely seamless look, with the channel not visible to the untrained eye.

FBC16 provides up to 42mm of glass adjustment.

Product Specifications

- Kits available to suit 12 - 21.52mm glass
- Width: 66mm, Height: 110mm
- Available in 3 and 6m lengths

Available Finishes

- Milled Aluminium

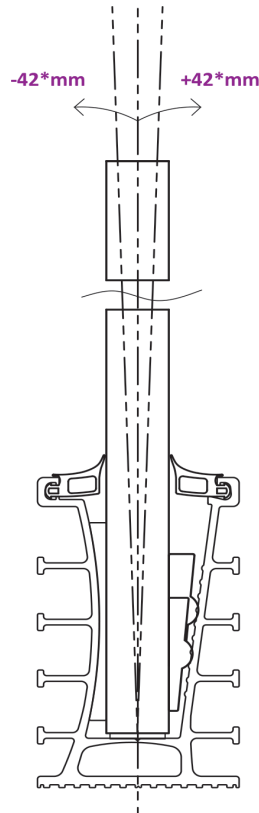

| Code | Description |
|----------------|---------------------------------|
| FBC16-3-KIT12 | 3m Length to suit 12-13.52mm |
| FBC16-6-KIT12 | 6m Length to suit 12-13.52mm |
| FBC16-3-KIT15 | 3m Length to suit 15-15.04mm |
| FBC16-6-KIT15 | 6m Length to suit 15-15.04mm |
| FBC16-3-KIT19 | 3m Length to suit 17.52-21.52mm |
| FBC-16-6-KIT19 | 6m Length to suit 17.52-21.52mm |

Kits include: Channel, Clamping Kits, Channel Cover & Rubber Seal.

Cover included to prevent debris entering the channel. Cover can then be removed when ready to install the glass.

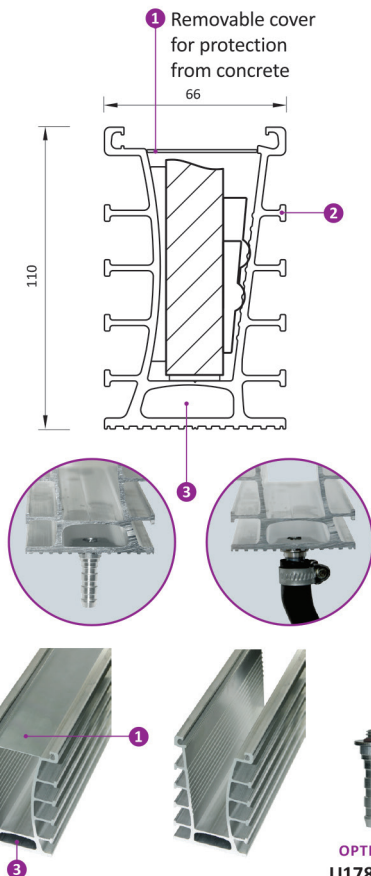

Dimensions: mm

1. Removable cover provides protection from debris entering the channel prior to installation.

2. Side nerves are designed for static strength within the concrete.

3. Inner chamber is also a drain collector which can be connected to the water extraction system.