

**real flame**  
the hearth of australia

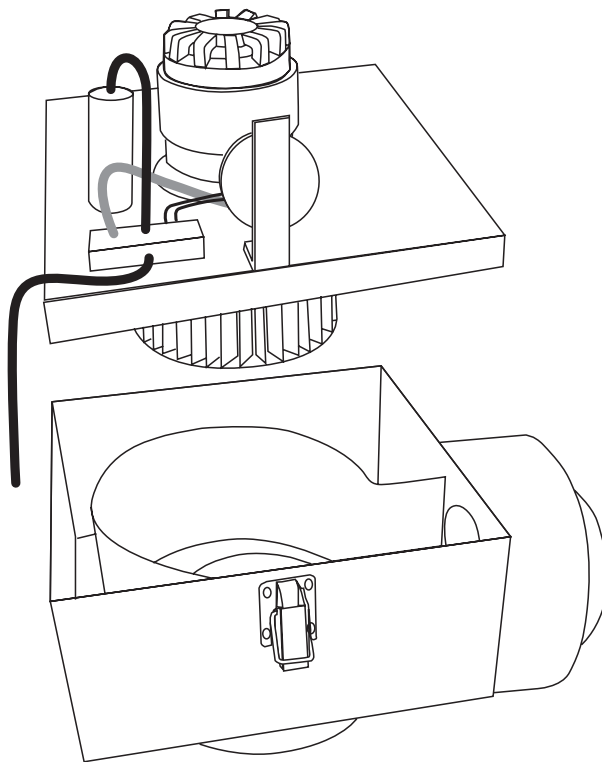

# **POWER FLUE®**

---

## **INSTALLATION & OPERATING MANUAL**

The Real Flame Power Flue system is approved to be installed with any open fronted Real Flame gas fireplace. Approval Number 6094.

VERSION 9

## WARRANTY

Provided your Real Flame Power Flue motor is installed in strict accordance with our installation instructions, the motor is unconditionally guaranteed or twelve months from date of purchase.

This unconditional warranty covers parts and labour at our discretion taking into consideration normal wear and tear and does not cover fires installed in outdoor settings.

## INSTALLATION NOTICE

- The installation of this appliance is only to be carried out by an authorised person in accordance with the manufacturers instruction, local gas fitting regulations, AG601 installation codes for gas burning appliances and any other relevant statutory regulations.

## IMPORTANT NOTES

The Real Flame power flue system is designed and manufactured by Real Flame and is approved to be installed with the following Real Flame Products.

- MAGIGLO 320 PF
- MAGIGLO 360 PF
- MAGIGLO 400 PF
- MAGIGLO 540 PF
- MAGIGLO 750 PF
- MAGIGOLO 540 DOUBLE
- HEATSEEKER FIREBOX MODELS 600, 700, 850, 1000
- HOTBOX FIREBOX
- REGISTER FIREBOX
- SIMPLICITY 850,1000, 1800
- ELEGANCE 850, 1000, 1800
- PURE VISION 850, 1000, 1800

*THE INSTALLATION MANUAL OF THE REAL FLAME POWER FLUE SYSTEM IS TO BE READ IN CONJUNCTION WITH THE INSTALLATION MANUAL OF THE REAL FLAME PRODUCT BEING USED.*

*THE DESIGN OF THE REAL FLAME POWER FLUE SYSTEM IS SUBJECT TO COPYRIGHT AND ALL INFRINGEMENTS WILL BE VIGOROUSLY PURSUED.*

# CONTENTS

Contents .....	3
Introduction .....	4
Installation .....	4
Power Flue Kit .....	9
Motor Clearance.....	8
Frameout .....	9
Motor exploded view .....	10
Dimensions .....	11
Internal Motor .....	12
External Motor .....	12
Troubleshooting Electronic Ignition and Power Flue System .....	13
Wiring Diagram .....	15
Parts List .....	15
Real Flame contact information .....	16

## INTRODUCTION - THE POWER FLUE SYSTEM

### POWER FLUE DESIGN

A 'flue' using a fan to remove or assist in removing combustion products from an appliance, is known as a 'power flue'.

### POWER FLUE APPLICATION

A power flue application can be used to enable a client to have a decorative fire with a horizontal flue run or a vertical flue run where flue space is inadequate for the normal flue.

## INSTALLATION INSTRUCTIONS

### VENTILATION REQUIREMENTS

Air supply to the unit is to be in accordance with ventilation Clause 5.4 of the Gas Code 601. Ventilation requirements do not change by using a power flue.

All Real Flame installation manuals have the ventilation areas clearly defined for each product.

### ACCESS TO POWER FLUE MOTOR

Access must be provided to the flue motor, this access **MUST** be at least 400mm x 400mm. There **MUST** be a minimum clearance of 250mm between the top of the motor and any fixed object i.e. ceiling or stud work. This is so the top of the fan box can be removed.

### WIRING OF THE POWER FLUE

All wiring for the power flue is carried out at the factory and plug connectors are fitted for easy installation. The power supply for the power flue is via a 3-pin plug at the rear of the firebox that can be plugged into a power socket within the cavity.

### ISOLATION SWITCH

If the power point is within a cavity an isolation switch accessible from outside the cavity must be provided.

### WIRING CLEARANCES

Wiring must at all times have a clearance of at least 150mm from the flue.

### FAN FAILURE SENSING DEVICE

All Real Flame Power Flue systems are fitted with a sensing device within the unit to ensure that, in the event of flow failure, the safety shut off valve within the module will go into lockout and shut off the gas supply to the unit.

### 'LOCKOUT'

'Lockout' is the term used when the module in the unit sensors a fault. When a fault is detected by the module it will shut off the gas and go into lockout. If this occurs contact the manufacturer.

# INSTALLATION INSTRUCTIONS (continued)

## LOCATION OF FLUE TERMINAL FOR POWER FLUE

Listed below are the minimum clearances required for fan-assisted terminations:

1. Below eaves, balconies and other projections. ....200mm
2. From the ground, above a balcony or other surface. ....300mm
3. From a return wall or external corner.....300mm
4. From a Gas meter. ....1000mm
5. From an electricity meter or fuse box.....500mm
6. From a drainpipe or soil pipe. ....75mm
7. Horizontally from any building structure or obstruction facing a terminal.....500mm
8. From any other flue terminal. Cowl, or combustion air intake. ....300mm
9. Horizontally from any openable window, door, non-mechanical air inlet, or any other opening into a building with the exception of sub floor ventilation. ....300mm
10. From a mechanical air inlet including a spa blower.....1000mm
11. Vertically below an openable window, non-mechanical air inlet, or any other opening into a building with the exception sub floor ventilation. ....500mm

## ELECTRICAL

**SHOULD THE SUPPLY FLEX AT THE BACK OF THE FIREBOX BE DAMAGED, A SPECIALLY PREPARED FLEX IS REQUIRED. FOR REPLACEMENT CONTACT THE MANUFACTURER.**

**THE ON/OFF WALL SWITCH MUST NEVER BE ATTACHED TO A METAL FRAME.**

## WARNING

**Whenever servicing the power flue system, always turn off the electrical power supply and close the manual gas control valve.**

### IMPORTANT INFORMATION

In addition to the instructions in this manual all national, state and local regulations must be adhered to. These include but are not limited to:

- Australian Standards AS3000 - Electrical Installation.
- Australian Standards AS5601 - Gas Installation.
- Local Gas and Electrical Authority Regulations.
- Municipal Building Codes.

The power flue should be serviced every 12 months by an authorised technician. If repairs are needed an authorised technician must carry them out.

## FITTING THE MOTOR

The Power Flue motor has a 150mm spigot and a twin spigot of 150mm & 200mm. The single spigot fits over the vertical flue and the 150/200mm flue attaches to the horizontal spigot.

## INSTALLATION INSTRUCTIONS (continued)

### FLUE SIZE

All flue prior to the motor is 150mm/200mm twin skin flue and all flue after the motor is 150mm/200mm twin skin

### HORIZONTAL FLUE RUN

The maximum length of horizontal flue run is to be 13.5 metres with a maximum of four (4) bends; these bends can be 45° or 90°. **The horizontal flue run is to have a grade downwards from the motor to the termination.**

### VERTICAL FLUE RUN (see page 7)

The minimum vertical flue run is 900mm from the top of the firebox (1500mm from the floor). If a longer vertical run is required twin skin flue 150mm & 200mm can be added between the muffler top and the fan. The flue can be cut to the required height.

### FLUE CLEARANCES

All flue clearances are as per the requirements listed in the heater specifications.

### TERMINATION

The termination to be used for all horizontal installations is to be 150mm cowl that has been approved as a horizontal cowl.

## INSTALLATION OF POWER FLUE KIT

### POWER FLUE MUFFLER

The power flue muffler has a spigot at each end. The end that attaches to the firebox has a spigot equivalent to the inner flue spigot diameter of the firebox, the top of the muffler has a 150mm spigot which the motor fits to, or the 150/200 twin skin flue if required. The flow arrow on the muffler is to be pointing up.

### WIRING (see wiring diagram page 15)

A 3 metre lead is supplied with the power flue, this lead has a different connection on each end, one end is plugged into the connection on the left hand side of the firebox and the other end is to be plugged into the fan. The wire coming from the rear of the firebox with the standard 3-pin plug attached is to be plugged into a power point. A single gang wall switch is also supplied attached to the 3 metres of lead; this wall switch is to be attached at a location accessible to the client. No other wiring is required.

### SERVICING OF THE POWER FLUE MOTOR

The Real Flame Power Flue motor is designed so as to make servicing the motor a simple task. The power lead connected to the motor is to be disconnected (unplugged) and the two side clips are to be undone, the fan motor will then lift out for servicing. The fan Motor box connected to the flue does not have to be disconnected from the flue.

# POWER FLUE KIT (Here shown with Heatseeker firebox)

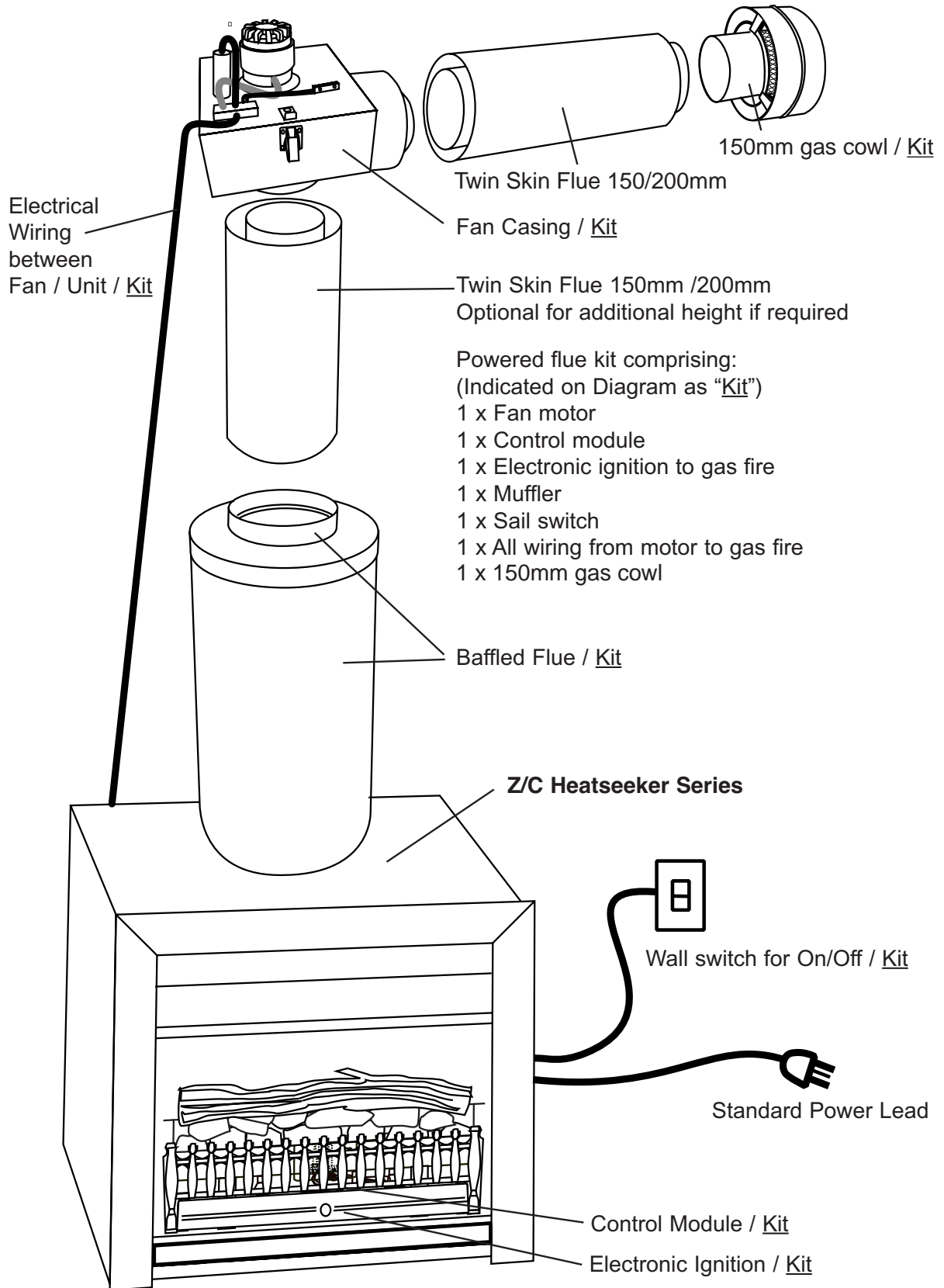

# POWER FLUE MOTOR CLEARANCE

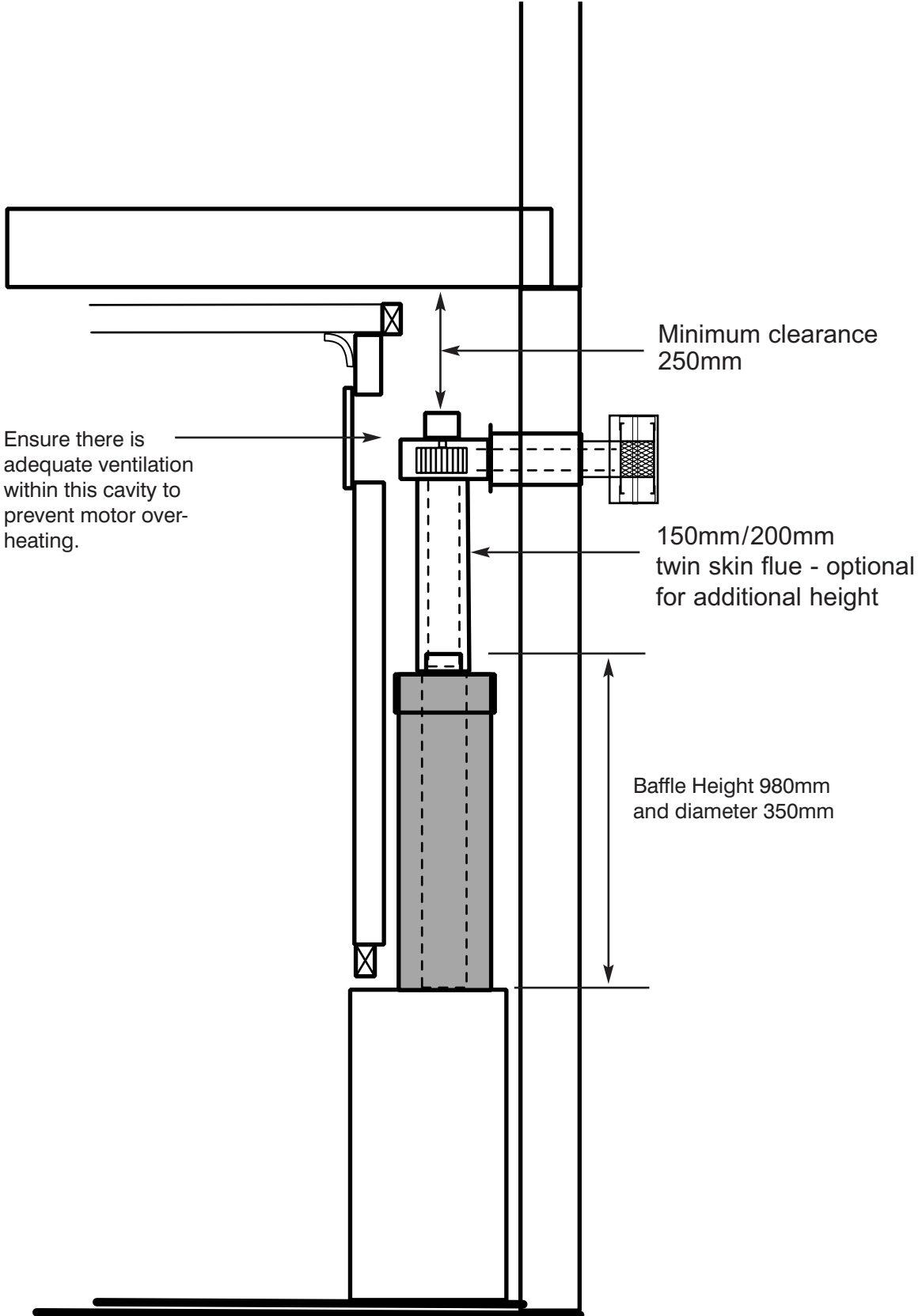



# TYPICAL POWER FLUE FRAMEOUT

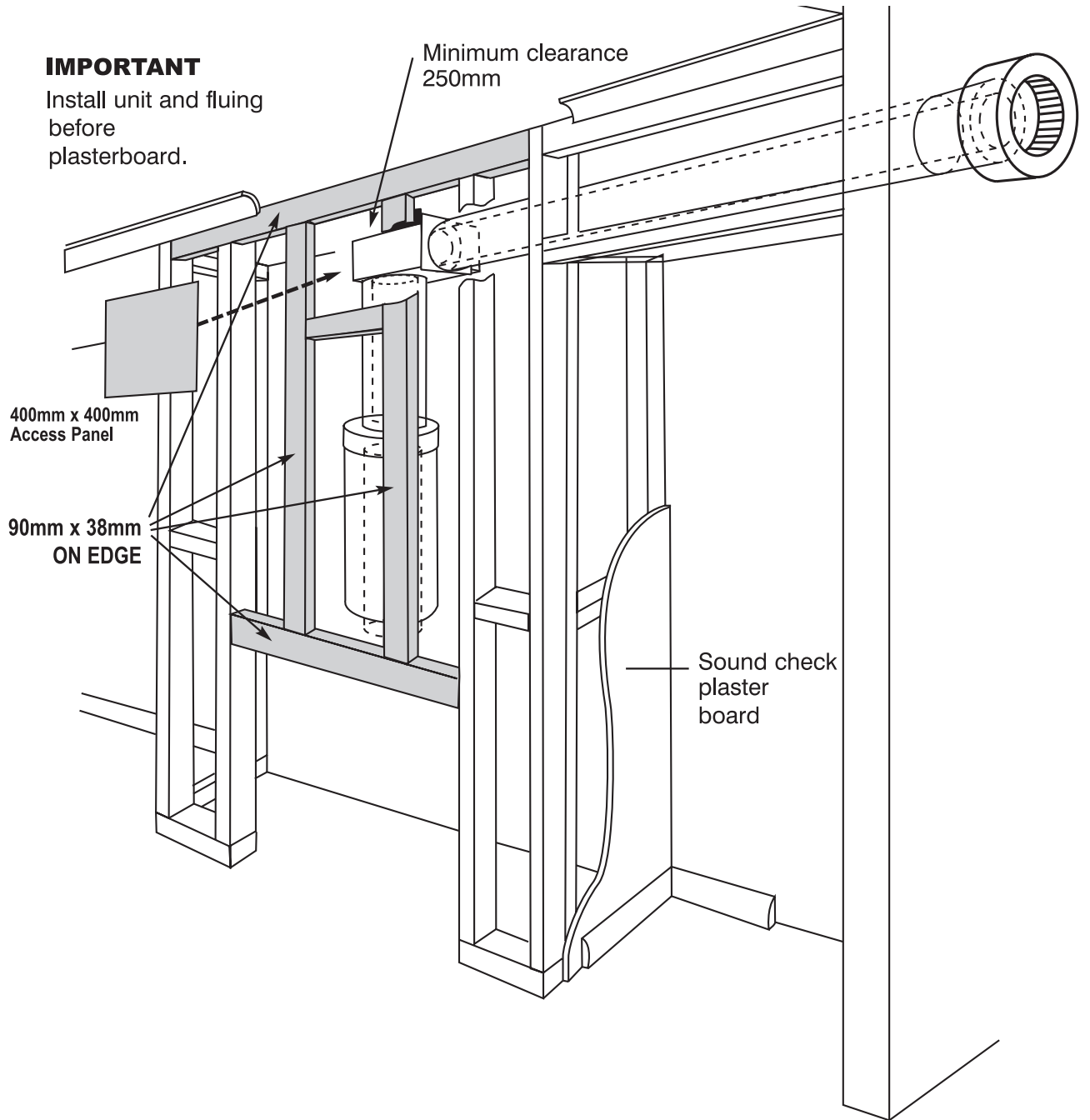

# POWER FLUE MOTOR

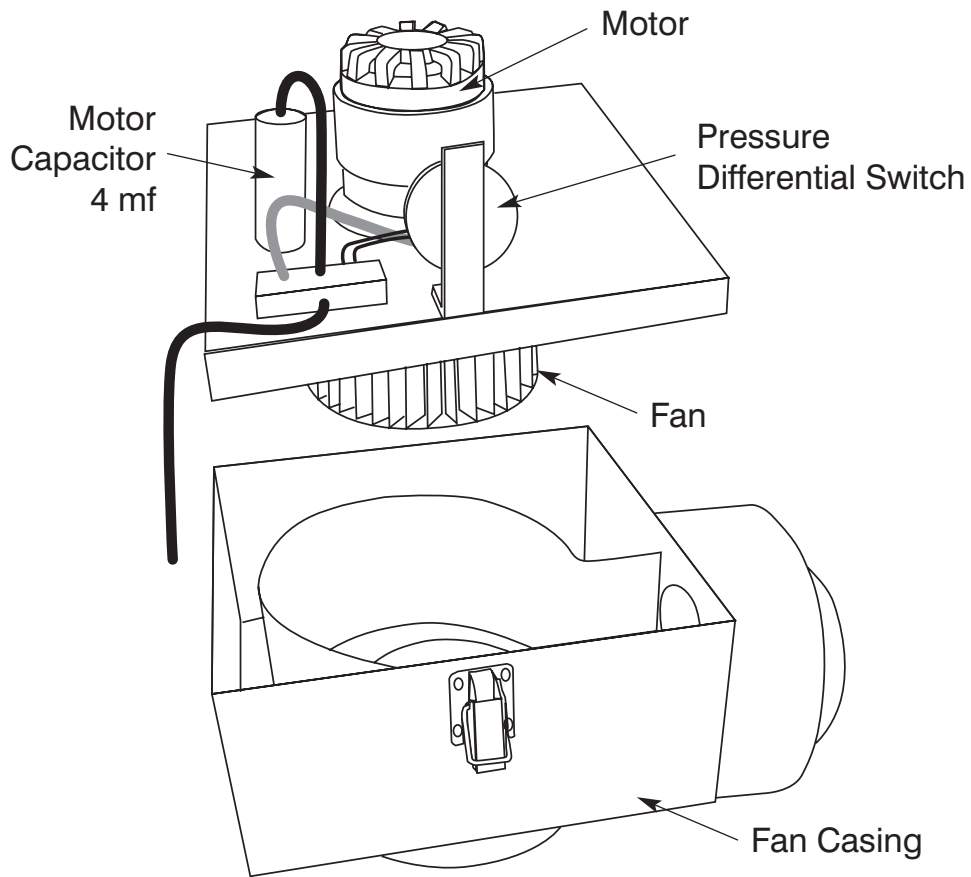

# DIMENSIONS

## Power Flue Motor

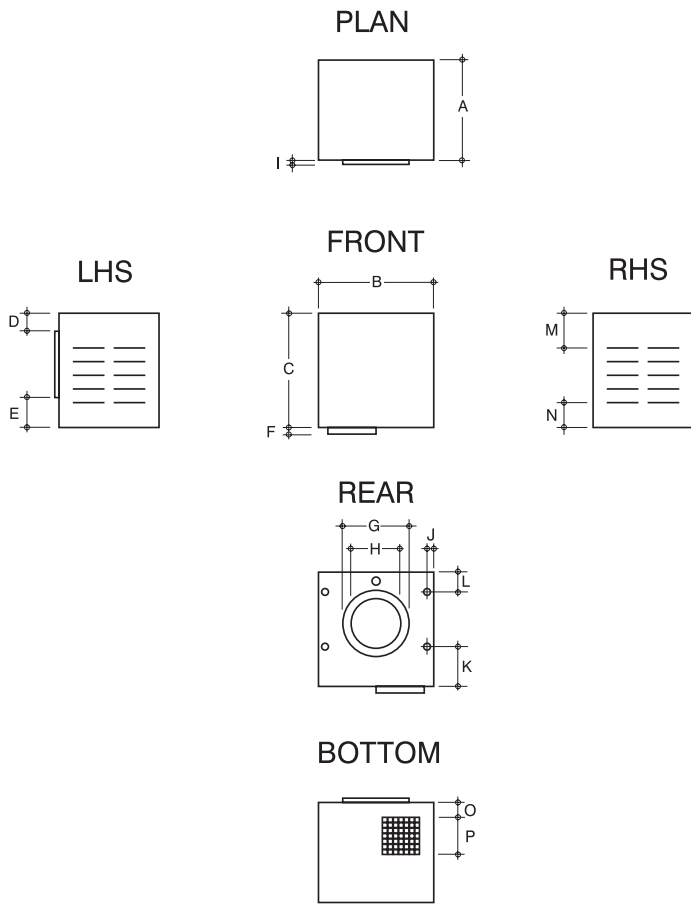

A	B	C	D	E	F	G	H
302	348	345	55	90	20	200	150

I	J	K	L	M	N	O	P
13	20	120	60	105	75	45	112

## Power Flue Flush Termination 500 x 500

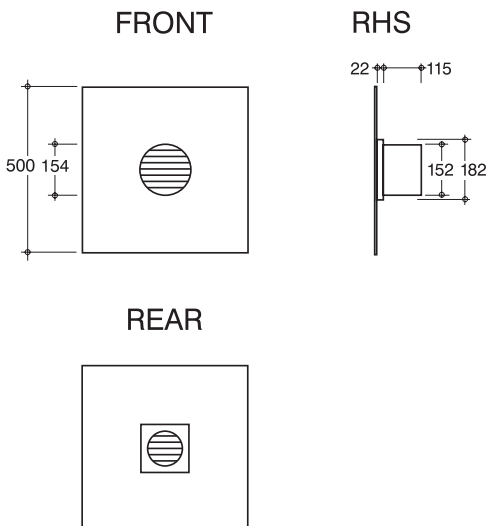

## Power Flue Flush Termination 300 x 300

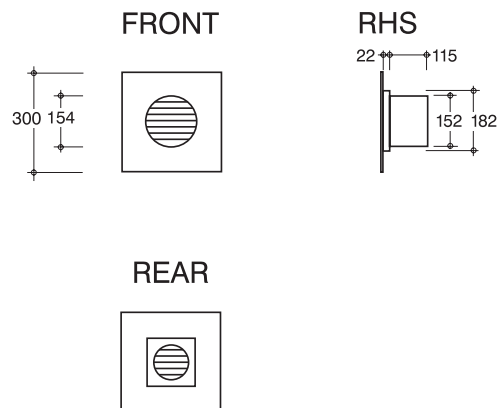

## INTERNAL MOTOR

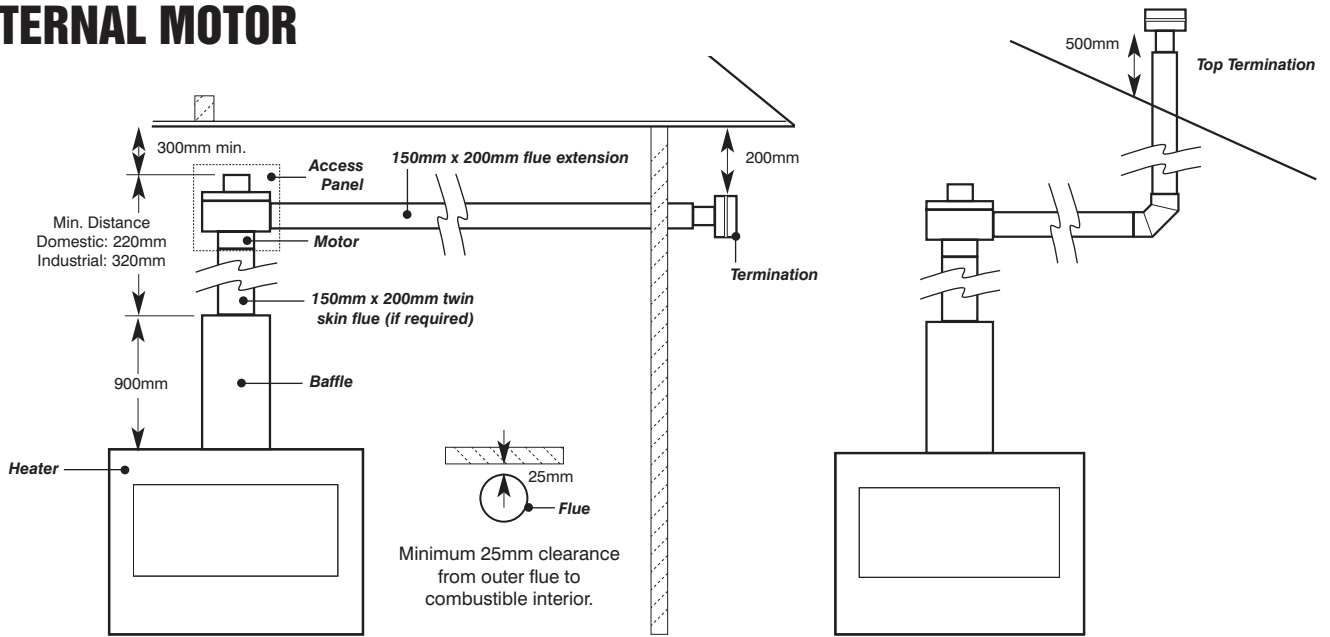

NOTE:

1. Maximum of 4 elbows, 45° or 90°.
2. Allow 400mm x 400mm access panel for service of motor.

## EXTERNAL MOTOR

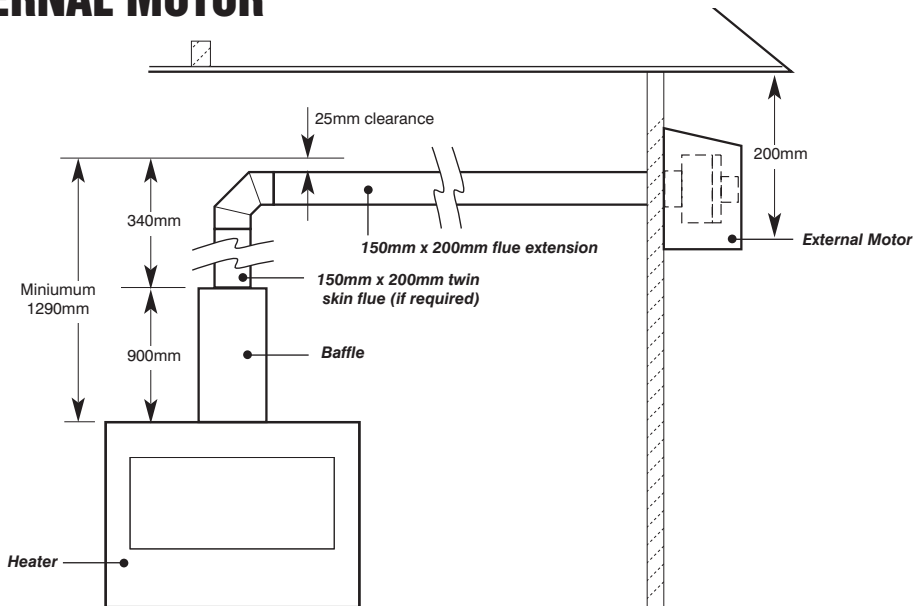

NOTE:

1. Maximum of 4 elbows, 45° or 90°.

## TROUBLE SHOOTING FOR ELECTRONIC IGNITION AND POWER FLUE SYSTEM.

Symptom	Possible Cause	Corrective Action
Fire turned on and nothing happens	No Power to Module	Connect Power
Fire turned on and motor starts but there is no spark	Pressure switch not operating	Check pressure switch
Fire sparks when turned on but will not ignite	A. No Gas	Connect Gas.
	B. Sparker is to far from metal	Adjust sparker so it cross lights to metal.
	C. Pressure switch (Power Flue) is not operating correctly.	Remove fan from housing and check that small tube supplying air to pressure switch has not moved or been damaged.
	C. Valve solenoids are faulty	Check solenoids
Fire ignites and then shuts down within a couple of seconds	D. Solenoid wires to module not connected correctly	Check that the four pin plug from the valve has been connected correctly
	A. Something is touching the heat sensor	Ensure that nothing is touching the sensor which is located behind the cover plate at front of burner.
Fire ignites and shuts down after several minutes	B. The power polarity is reversed	Check polarity
	A. Insufficient air for burner to operate correctly	Check that the unit has correct ventilation as per Installation manual.
	B. Pressure switch not operating correctly	Check air supply tube to pressure switch.

## **TROUBLE SHOOTING FOR ELECTRONIC IGNITION AND POWER FLUE SYSTEM.** (continued)

The power flue and electronic control box have a red LED light that indicates the possible cause of a problem, the LED light will flash in different sequences for different problems, the most common are:-

Long Flash	Short Flash	
1	0	Normal Running State.
1	1	Flame Failure.
1	2	Waiting for pressure switch ON
1	3	Waiting for pressure switch OFF
2	1	Maximum retries exceeded

# POWER FLUE WIRING DIAGRAM

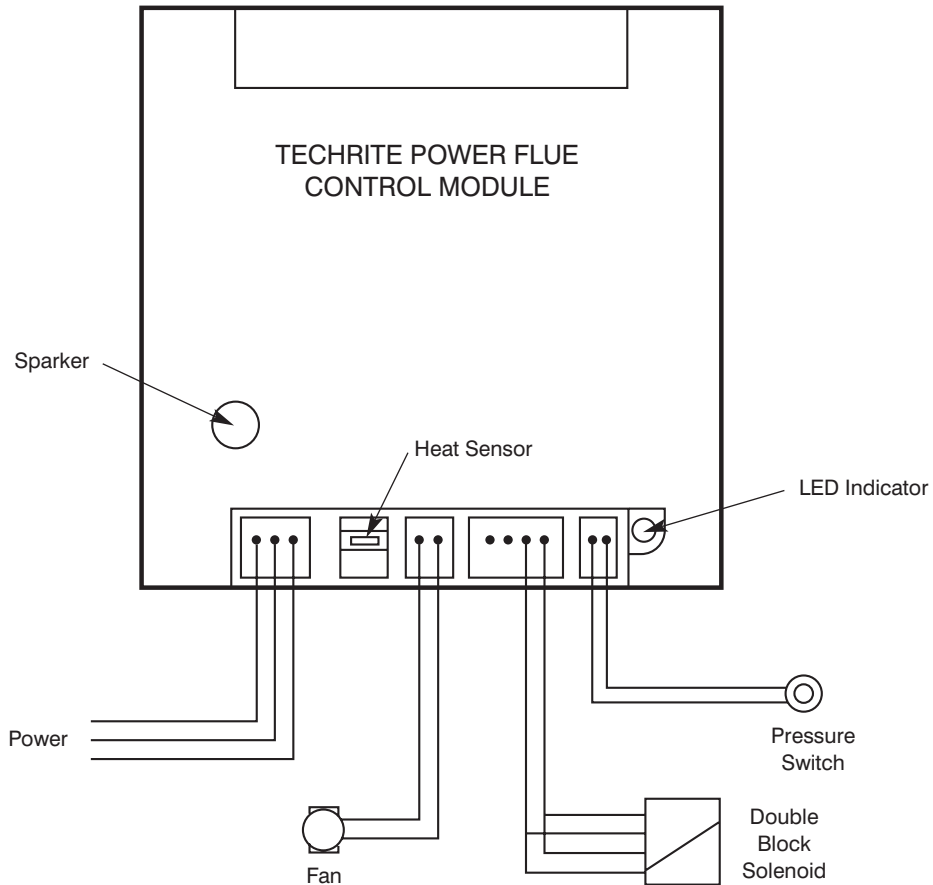

## NOTE

For C Bus and/or fresh air damper interlock systems, please contact us for wiring diagrams and relevant system instructions at [info@realflame.com.au](mailto:info@realflame.com.au)

## PARTS LIST

PART No.	DESCRIPTION
1.	Dungs BM.740-007 double block solenoid valve
2.	Dungs DGAI.73 Module 5.1.3.
3.	Electronic Ignition Sparker
4.	Electronic Flame Sensor
5.	Ecofit 2GTA35 Motor. Complete with 'sail' switch.
6.	900mm Real Flame Power Flue Muffler.



**real flame**  
the hearth of australia

**REAL FLAME PTY LTD**

ABN 76 006 311 155

**Head Office/Factory/Showroom**

1340 Ferntree Gully Rd.  
Scoresby Vic 3179  
Ph: (03) 8706 2000 Fax: (03) 8706 2001  
E-mail: [info@realflame.com.au](mailto:info@realflame.com.au)

**Richmond - VIC Showroom**

300 Swan St.  
Richmond Vic 3121  
Ph: (03) 9428 4443 Fax: (03) 9428 4445

**Dandenong - VIC Showroom**

9 Lonsdale St.  
Dandenong Vic 3175  
Ph: (03) 9791 9285 Fax: (03) 9791 9662

**Geelong - VIC Showroom**

1/2A Gordon Avenue.  
Geelong West Vic 3218  
Ph/Fax: 5229 0844  
E-mail: [realflamegeelong@hotmail.com.au](mailto:realflamegeelong@hotmail.com.au)

**Sydney - NSW Showroom**

654 Pacific Highway.  
Chatswood NSW 2067  
Ph: (02) 8905 0189 Fax: (02) 8905 0192  
E-mail: [info@realflame.com.au](mailto:info@realflame.com.au)

**Miranda - NSW Showroom**

36 Kareena Rd  
Miranda NSW 2228  
Ph: (02) 8513 6202 Fax: (02) 9520 1974  
E-mail: [paul@realflamemiranda.com.au](mailto:paul@realflamemiranda.com.au)

**Adelaide - SA Showroom**

173 -175 Magill Rd.  
Norwood SA 5067  
Ph: (08) 8132 0371 Fax: (08) 8132 1687  
E-mail: [realflamesa@iprimus.com.au](mailto:realflamesa@iprimus.com.au)

**Miton - QLD Showroom**

46 Douglas St,  
Milton QLD 4064  
Ph: (07) 3368 2011

**Perth - WA Showroom**

47-53 McDonald St East,  
Osborne Park WA 6017  
Ph: (08) 9444 9900 Fax: (08) 9444 9800

**Fyshwick - ACT Showroom**

88 Wollongong St,  
Fyshwick ACT 2609  
Ph: (02) 6280 5522